

Features

HIGH CURRENT CARRY AND HIGH VOLTAGE

Inert gas filled arc chamber suitable for high voltage switching

COMPACT STRUCTURE, LOW NOISE

Small, low-profile design with low noise while carrying or switching loads

COIL ECONOMIZER

Economized coil for low power consumption

SAFE FOR EXPLOSIVE ENVIRONMENTS

No arc leakage due to a hermetically sealed design

HIGH RELIABILITY DESIGN

Hermetic sealing creates a stable environment for high voltage switching

VARIOUS APPLICATIONS

Battery disconnect, EV charging, energy storage systems, photovoltaics, power control, circuit protection and much more

Sealing Type: Epoxy/Resin

- ✓ Perfect for energy storage applications



Certification Information

1. Meet RoHS (2011/65/EU)
2. CE certified
3. UL approved

Nomenclature

AES600

M

A

Series code:

“AES600” = AES600 Series

Coil Voltage Code:

“C” = 24VDC (Low Inrush Current)

“M” = 12 - 24VDC

Options (applied in this order):

“A” = Std. Options (Bottom Mount, With Aux.

Contact (SPST-NO) & Polarized Load Terminals)

Product Data Sheet

MAIN CONTACT

Contact Arrangement	1 Form X (SPST-NO)	
Rated Operating Voltage	1000VDC	
Rated Current	600A	
Max Short Circuit Current	2000A (30s)	
Short Term Current	1200A (1min)	
Dielectric Withstanding Voltage (initial)	Between Open Contacts	3500 VAC/5mA/60s
	Between Contacts to Coil	3500 VAC/5mA/60s
Insulation Resistance (Initial)	Terminal to Terminal	Min. 100 MΩ@500VDC
	Terminals to Coil	
Contact Voltage Drop (initial)	Max. 50mV/100A	

OPERATE / RELEASE TIME

Operate Time	40ms, Max. @20°C
Release Time	15ms, Max. @20°C

ENVIRONMENTAL DATA

Shock	Functional	196m/s ² Sine half-wave pulse
	Destructive	490m/s ² Sine half-wave pulse
Operating Temperature	-40 to +85°C	
Humidity	5% to 85%RH	
Weight	2.03 Lb. (920g)	

EXPECTED LIFE

Electrical Endurance	600A@450VDC 1000 Cycles
Mechanical Life	200,000 Cycles

COIL DATA

Nominal Voltage	12-24VDC	24VDC
Max. Voltage (20°C)	36VDC	32VDC
Pick-up Voltage (20°C)	8-9VDC	18VDC
Drop-out Voltage (20°C)	5-7VDC	11VDC
Max. Inrush Current (20°C)	4A	0.55A
Avg. Holding Current (20°C)	0.29A@12VDC	0.13A@24VDC
	0.15A@24VDC	
	0.09A@36VDC	

Current Carry Curve (300m² conductor)

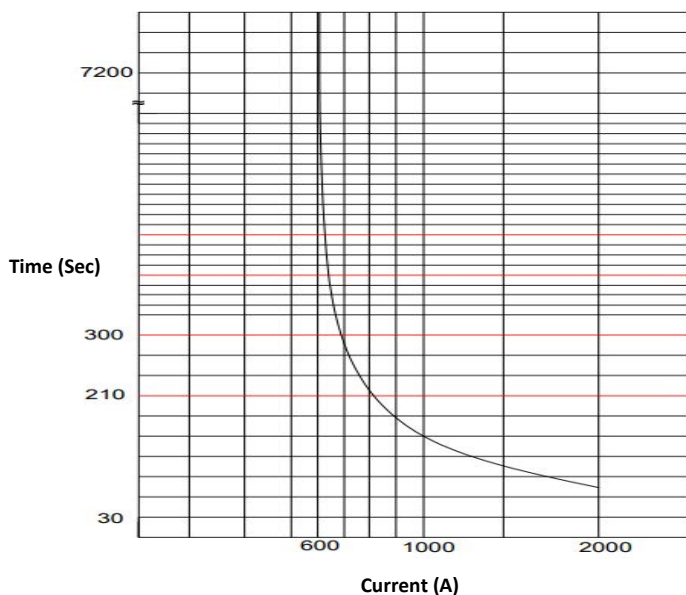

AUX. CONTACT

Aux. Contact Arrangement	1 Form A
Aux. Contact Current Max.	3A@24VDC/3A@125VAC
Aux. Contact Current Min.	100mA@8V

Electrical Life

Estimated Make and Break Resistive Load Ratings

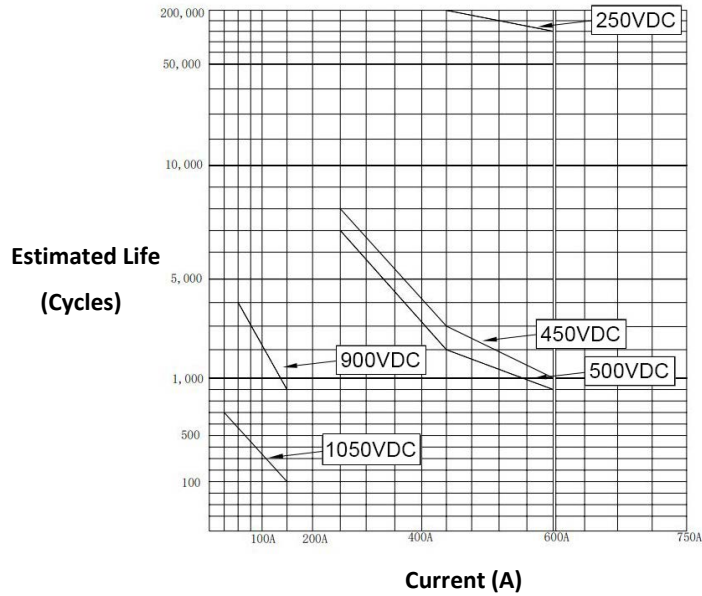

Outline Dimensions : inches (mm)

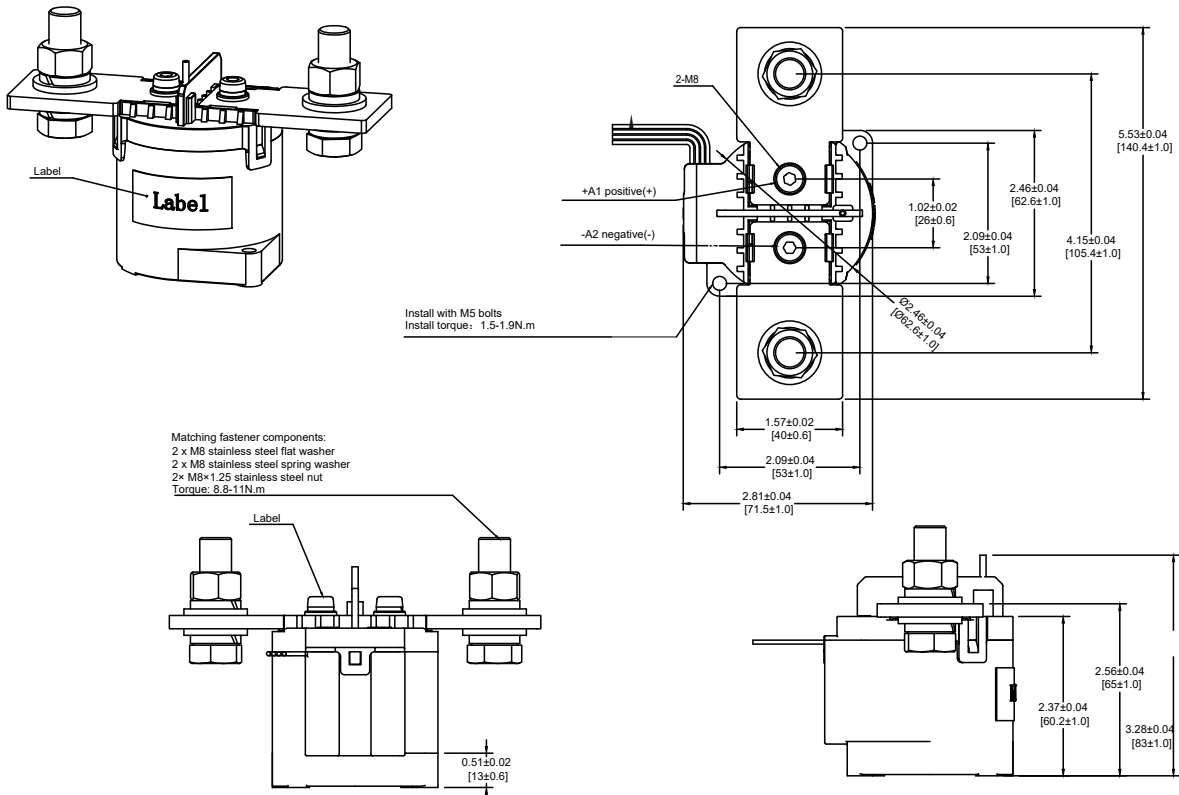

Note:
 The wire length is 15.4±0.4 (390 ± 10)

Part Number	Wire Diameter
AES600-CA	28AWG
AES600-MA	22 AWG

Application Notes

1. To prevent loosening, split washers should be used whenever the contactor is installed. All terminals or conductors must be in direct contact with the contactor's main terminals. Please control the tightening torque of each part within the specified range in the table below. If the torque exceeds the recommended range, it may cause damage to the sealed cavity and thread damage.
 - Contact torque: : 24-30 N.m
 - Mounting torque: 2.3 N.m Max.
2. Products with a coil economizer are already equipped with back EMF circuits, so there is no need to use surge protectors.
3. Products with polarity marked on the load end must be used correctly according to the product label. When the load connection polarity is reversed, the electrical characteristics in this data sheet cannot be guaranteed
4. Avoid installing the contactor in a strong magnetic field environment (near transformers or magnets) and avoid placing the contactor near objects with heat radiation.
5. When continuous current is applied to the contacts of the relay, and the coil is turned on immediately after the power is cut off. At this time, as the temperature of the coil increases, the resistance of the coil will also increase, which will increase the pull-in voltage of the product, which may result in exceeding the rated pull-in voltage. In this case, the following measures should be taken to reduce the load current; limit the continuous power-on time or use a coil voltage higher than the rated pull-in voltage.
6. When the voltage applied to the coil exceeds the maximum allowable applied voltage, the coil temperature may rise and lead to coil damage and inter-layer short circuit.
7. The rated values in the contact parameters are values for resistive load. When using an inductive load with $L/R > 1\text{ms}$, please connect a surge current protection device to the inductive load in parallel. If no measures are taken, the electrical life may be reduced and the continuity may be poor. Please consider sufficient margin space in the design.
8. Coil drive power must be greater than coil power or it will reduce performance capability.
9. Please do not allow debris and oil to adhere to the main terminals; Make sure that the main terminals are in reliable contact with the load conductor, otherwise the temperature rise of the terminal/conductor connection may be too high due to the excessive contact resistance.
10. The load conductor must have the corresponding current load capacity and heat dissipation capacity (it is recommended to use a copper bar with min 300mm^2), to prevent overheating and affecting the life of the contactor.
11. It is impossible to determine all the performance parameters of contactors in each specific application, therefore, customers should choose the products matching them according to their own conditions of use. If in doubt, contact Altran. The customer will be responsible for validating that the products meet their application.
12. Do not use if dropped.
13. Altran reserves the right to make changes as needed. Customers should reconfirm the contents of the specification or ask for us to supply a new specification if necessary.